

DC-ATCO

Direct Current Thermal-Link (Alloy Type)

RQF Series

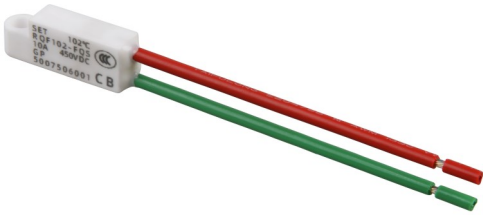

Description

The Direct Current Thermal-Link Alloy Type (DC-ATCO) is defined as a non-resettable protective device functioning only once. It is widely used for over-temperature protection of electrical equipment and electric vehicles. The DC-ATCO primarily consists of Case, Filler material, Fuse, Flux Resin, a low melting point Thermal Element, Electrode, Sealant and Stranded Conductor. Normally, the Thermal Element is joined to the two lead wires. When the temperature reaches the fusing temperature of the Direct Current Thermal-Link (Alloy Type), the Thermal Element melts and quickly retracts to the two lead wire ends with the aid of the flux resin, disconnecting the circuit completely. The SETsafe | SETfuse Direct Current Thermal-Link (Alloy Type) is classified into Axial and Radial shapes, with a Rated Functioning Temperature ranging from 86 °C to 187 °C, Rated Current 10 A, Rated Voltage 450 VDC, and it holds CCC, CB Approvals. It is also RoHS and REACH compliant.

Marking

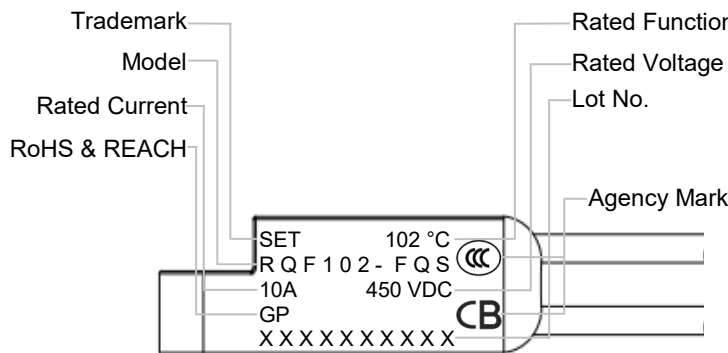

Structure Diagram

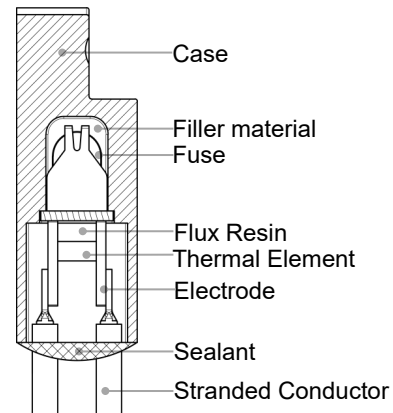

Product Schematic

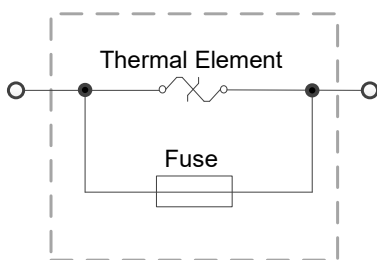

Features

- 0 to 450 VDC Operating Voltage
- High Accuracy of Functioning Temp.
- Ceramic Case
- Non-Resettable
- RoHS & REACH Compliant

Applications

- Battery Cooling Heaters
- Air-Conditioners Heaters
- Pre-charged Resistors
- High Power LED

Customization

- Rated Functioning Temp.
- Stranded Conductor Size

Agency Information

Agency Symbol	Standards	The File No. and certification No. obtained by SETsafe SETfuse
CB	IEC 60691-2015	CN59823
CCC	GB 9816.1-2013	2023000205000006

DC-ATCO

Direct Current Thermal-Link (Alloy Type)

RQF Series

Part Number System

RQF102 - F Q S

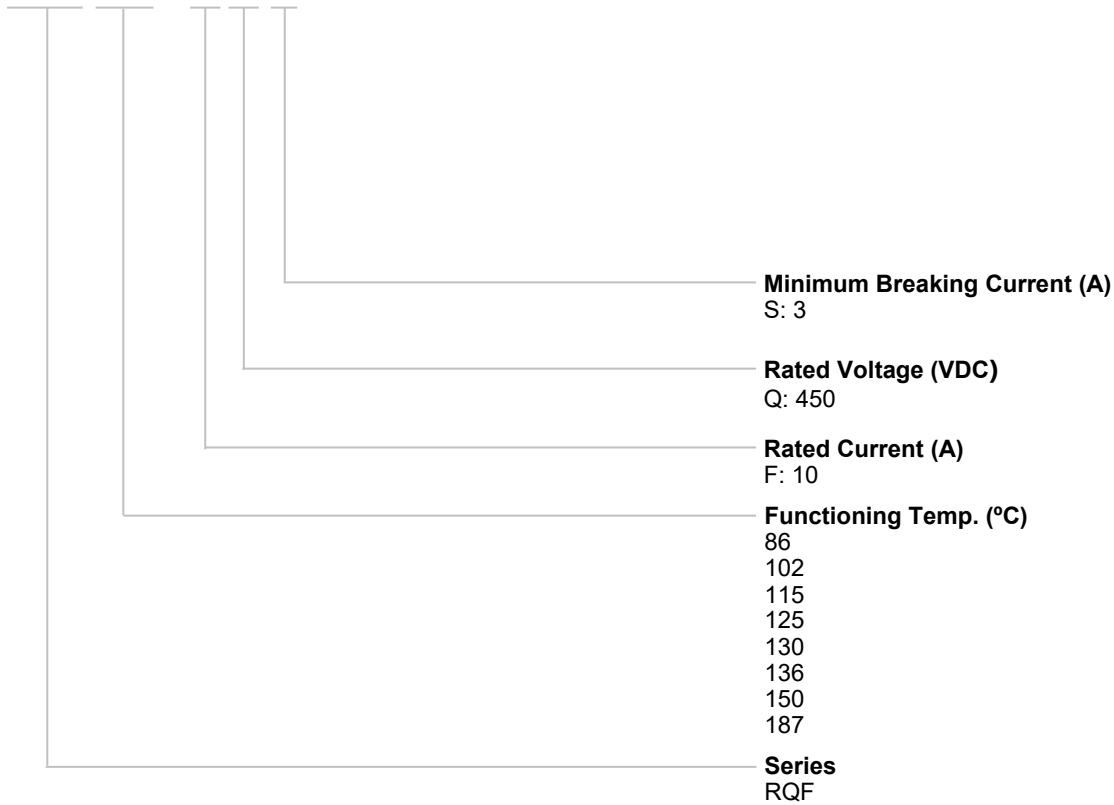

Dimensions (Unit: mm)

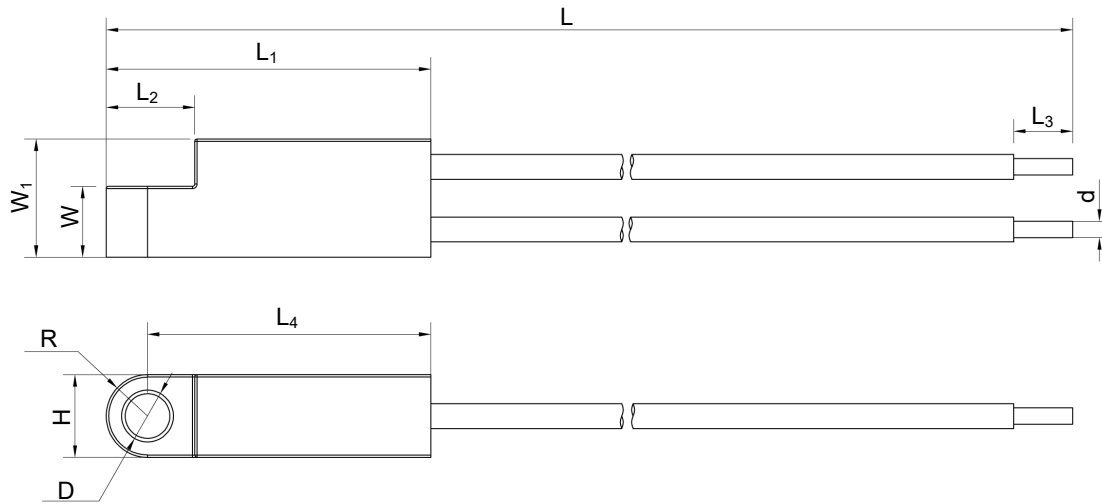

L	L ₁	L ₂	L ₃	L ₄	W	W ₁	H	R	D	d
127.5 ± 5.0	27.5 ± 1.0	7.5 ± 0.5	5.0 ± 0.5	24.0 ± 1.0	6.0 ± 0.5	10.0 ± 0.5	7.0 ± 0.5	3.5 ± 0.2	3.8 ± 0.2	AWG16

Specifications

Rated Functioning Temp. (T _f) °C	Model	I _r	U _r	Rated Functioning Temp.	T _h	T _m	I _{min}	CB	CCC	RoHS REACH
		(A)	DC (V)	(°C)	(°C)	(°C)	(A)	CB	CCC	
187	RQF187-FQS	10	450	182 ⁺⁵ ₋₃	155	250	3	○	○	●
150	RQF150-FQS	10	450	146 ± 3	115	250	3	○	○	●
136	RQF136-FQS	10	450	131 ± 3	100	250	3	○	○	●
130	RQF130-FQS	10	450	126 ± 3	95	250	3	○	○	●
125	RQF125-FQS	10	450	122 ± 3	85	250	3	○	○	●
115	RQF115-FQS	10	450	112 ± 3	85	250	3	○	○	●
102	RQF102-FQS	10	450	99 ⁺⁵ ₋₃	75	250	3	●	●	●
86	RQF86-FQS	10	450	81 ± 3	45	250	3	○	○	●

Note:

1. "●" Means certificated, "○" Means non-certificated.
2. RoHS & REACH Comply.

Temp.-Time Curve

The functioning temperature time curve of Alloy Thermal-Link in different Temp. oil bath (For reference only).

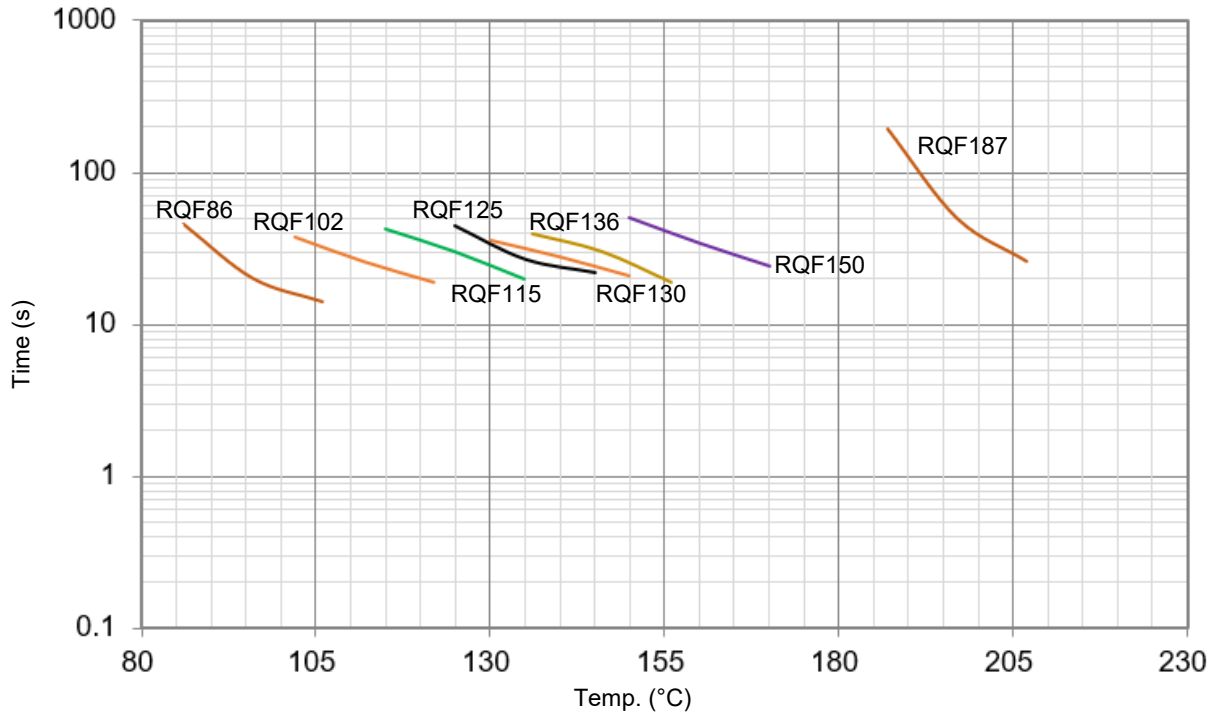

Current-Time Curve

This is an illustrated curve, describing the opening time at Multi-times rated current in the condition of the room Temp. 25 °C (For reference only).

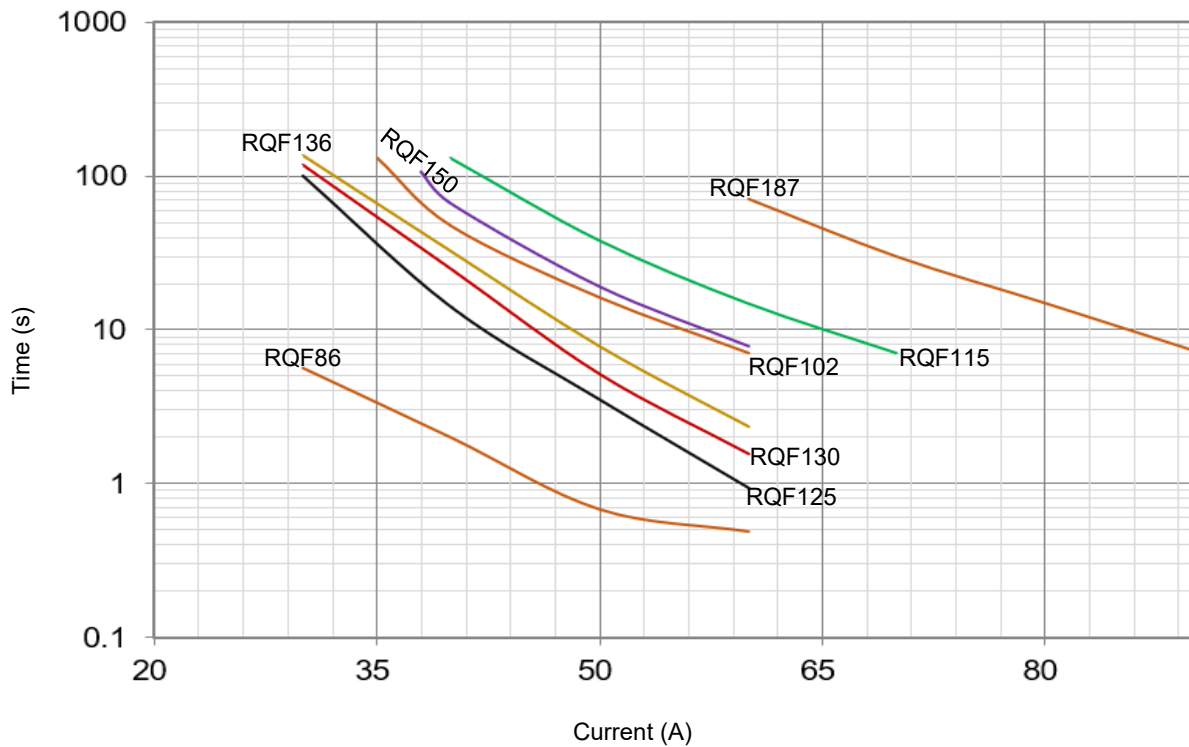

Packaging Information

Item	PE Bag	Box	Carton
Dimensions (mm)	140 x 94	245 x 165 x 67	365 x 260 x 385
Quantity (PCS)	5	100	1000
Gross Weight (kg)			10 ± 10%

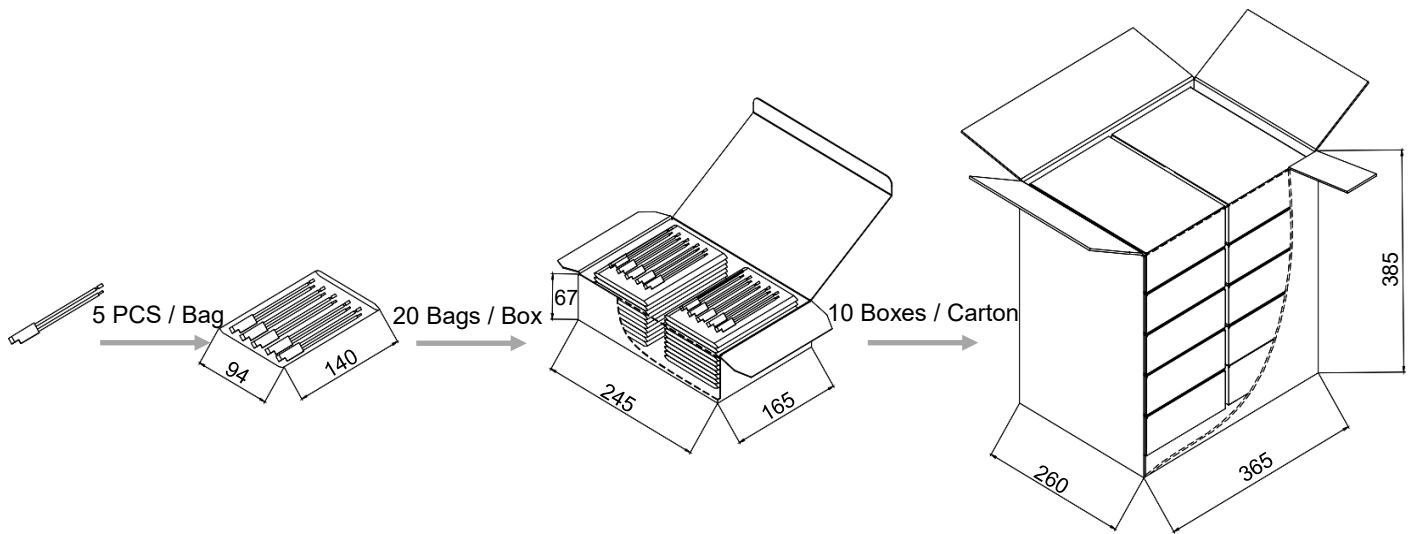

Glossary

Item	Description
DC-ATCO	DC-Alloy Thermal-Link DC-Alloy type Thermal-Link, Alloy is thermal element.
T_f	Rated Functioning Temp. The temperature of the Thermal-Link which causes it to change the state of conductivity with a detection current up to 10 mA as the only load. Tolerance: T_f (0 / -10) °C (GB 9816, EN 60691, K60691). Tolerance: $T_f \pm 7$ °C (J60691).
Fusing Temp.	Fusing Temp. The temperature of the Alloy Thermal-Link which causes it to change its state of conductivity is measured with silicone oil bath in which the temperature is increased at the rate of 0.5 °C to 1 °C / minute, with a detection current up to 10 mA as the only load.
T_h	Holding Temp. The Maximum temperature at which a Thermal-Link will not change its state of conductivity when conducting rated current for 168 hours.
T_m	Maximum Temp. Limit The temperature of the Thermal-Link stated by the manufacturer, up to which the mechanical and electrical properties of the Thermal-Link having changed its state of conductivity, will not be impaired for a given time.
I_{min}	Minimum Breaking Current The minimum current that Fuse requires after the Alloy of Thermal-Link opens in the circuit.
I_r	Rated Current The current used to classify a Thermal-Link, which is the maximum current that Thermal-Link allows to carry and is able to cut off the circuit safely.
U_r	Rated Voltage The voltage used to classify a Thermal-Link, which is the maximum voltage that Thermal-link allows to carry and is able to cut off the circuit safely.



ATTENTION

Usage

1. When atmosphere pressure is from 80 kPa to 106 kPa, the related altitude shall be from -500 m to 2000 m.
2. Operating voltage less than rated voltage of DC-ATCO, operating current less than rated current of DC-ATCO.
3. Do not touch the DC-ATCO body or lead wires directly when power is on, to avoid burn or electric shock.

Replacement

DC-ATCO is a non-repairable product. For safety sake, it shall be replaced by an equivalent DC-ATCO from the same manufacturer, and mounted in the same way.

Storage

Do not store the DC-ATCO at the high temp., high humidity or corrosive gas environment. The product shall be stored at 25 ± 5 °C and $\leq 70\%$ RH, avoid direct sunlight and shall use them up within 1 year after receiving the goods.

Installation

Make Sure the Temp. of Installation Position

1. It is recommended that a dummy DC-ATCO with inbuilt thermo-couple shall be used to determine the proper temp.
2. The terminal product should be tested to ensure that potential abnormal conditions do not cause ambient temp. to exceed the T_m of the DC-ATCO.
3. Mount the DC-ATCO at the location where temp. rises evenly.

Installation position of mechanical performance requirements

1. Ensure that the lead wire is long enough, and avoid actions such as press, tensile or twist.
2. The seal or body of DC-ATCO must not be damaged, burned or over heated.

Mechanical Connection

Riveting

1. Choose small resistivity riveting material and be riveted.
2. A flexible lead or lead with low resistance should be used to rivet the DC-ATCO.
3. Contact resistance should be minimal, Large contact resistance will lead to higher temp., DC-ATCO Functioning in advance.

Soldering

Hand-Soldering

1. Soldering should be carried out according to Table T-1.
2. The thermal element of DC-ATCO is thermal element with low melting point, which is jointed with DC-ATCO lead wires. Improper soldering operation (too high soldering temp. , too long soldering time, too short lead wire etc.) may transfer more heat to the thermal element and DC-ATCO may open in advance.
3. When soldering conditions are more severe than those listed in Table T-1, a heat sink fixture should be used between soldering point and DC-ATCO body.
4. When soldering, please do not pull / push or twist DC-ATCO body or lead wires.
5. After soldering, let it naturally cool for longer than 20 seconds. During cooling, never move the DC-ATCO body or lead wires.

TABLE T-1 Hand-Soldering Time

Rated Functioning Temp. (T_f)	Max. Allowable Soldering Time for Different Lead Wire Length (Fig.H-1)						Max. Soldering Temp.
	Length	Time	Length	Time	Length	Time	
		Tinned Copper Wire		Tinned Copper Wire		Tinned Copper Wire	
(°C)	(mm)	(s)	(mm)	(s)	(mm)	(s)	(°C)
76 ~ 101	10	1 ^a	20	2	30	3	400
102 ~ 115	10	1 ^a	20	2	30	3	
116 ~ 135	10	1 ^a	20	3	30	5	
136 ~ 150	10	3	20	5	30	5	
151 ~ 230	10	4	20	6	30	7	

a: Auxiliary heat sink fixture is required to avoid DC-ATCO cutting off unexpectedly.

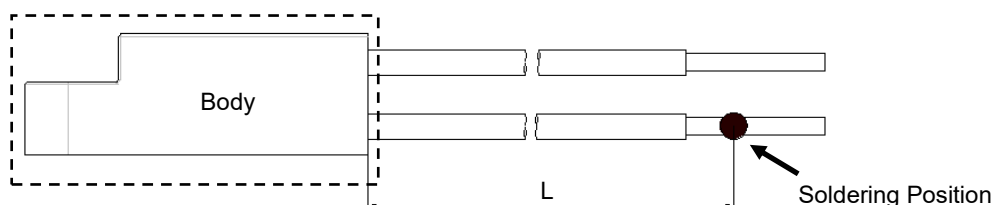

FIGURE T-1

Lead Wire Forming

1. If lead wire has to be bent, please pay attention to the distance between body and bending point. Refer to Table T-3.
2. When bending leads, please use pincher or similar tools to fix the product as shown in Figure T-2 to avoid damaging the product.
3. During forming and mounting, lead wire should not be cut, nicked, bent sharply, to avoid breaking the product.
4. Tangential forces on the leads must be avoided (i.e. pushing or pulling on the leads at angle to DC-ATCO body) as such forces may damage the seal of DC-ATCO.

Bending radius $R: \geq 15 d$, as shown in Figure T-2.

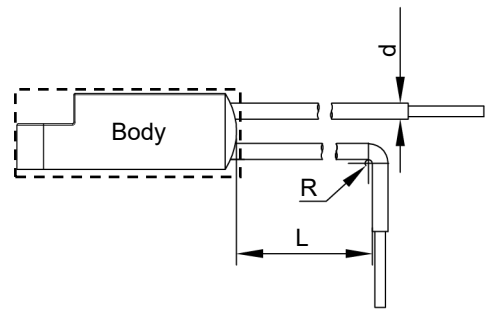





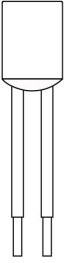





FIGURE T-2

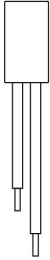



TABLE T-3 Distance between Body and Bending Point

Lead Wire	d	(mm)	< 1.0	1.0 to 1.2	> 1.2
	L	(mm)	≥ 3	≥ 5	≥ 10

Direct Current Thermal-Link Alloy Type (DC-ATCO) Features & Model List Overview

Rated Functioning Temp. (T_f) °C	Model								
	TGH187-HVS [^]	ASL187A-LSF [^]	RSK187A-KSS [^]	RVH187-HSF [^]	ARL187-LRA [^]			RQF187-FQS [^]	
230	○	○	○	○	○	○	○	○	○
221	○	○	○	○	○	○	○	○	○
205	○	○	○	○	○	○	○	○	○
200	○	○	○	○	○	○	○	○	○
187	TGH187-HVS [^]	ASL187A-LSF [^]	RSK187A-KSS [^]	RVH187-HSF [^]	ARL187-LRA [^]	○	○	RQF187-FQS [^]	○
160	○	○	○	○	○	○	○	○	○
150	TGH150-HVS [^]	ASL150A-LSF [^]	RSK150A-KSS [^]	RVH150-HSF [^]	ARL150-LRA [^]	RPK150-HRZ [^]	TG150C-HQZ [^]	RQF150-FQS [^]	TG150C-JPZ [^]
145	○	○	○	○	○	○	○	○	○
139	○	○	○	○	○	○	○	○	○
136	TGH136-HVS [^]	ASL136A-LSF [^]	RSK136A-KSS [^]	RVH136-HSF [^]	ARL136-LRA [^]	RPK136-HRZ [^]	TG136C-HQZ [^]	RQF136-FQS [^]	TG136C-JPZ [^]
135	○	○	○	○	○	○	○	○	○
133	○	○	○	○	○	○	○	○	○
130	TGH130-HVS [^]	○	○	RVH130-HSF [^]	○	○	○	RQF130-FQS [^]	○
125	TGH125-HVS [^]	ASL125A-LSF [^]	RSK125A-KSS [^]	RVH125-HSF [^]	ARL125-LRA [^]	RPK125-HRZ [^]	TG125C-HQZ [^]	RQF125-FQS [^]	TG125C-JPZ [^]
123	○	○	○	○	○	○	○	○	○
120	○	○	○	○	○	○	○	○	○
115	TGH115-HVS [^]	ASL115A-LSF [^]	RSK115A-KSS [^]	RVH115-HSF [^]	ARL115-LRA [^]	RPK115-HRZ [^]	TG115C-HQZ [^]	RQF115-FQS [^]	TG115C-JPZ [^]
105	○	○	○	○	○	○	○	○	○
102	TGH102-HVS [^]	ASL102A-LSF [^]	RSK102A-KSS [^]	RVH102-HSF [^]	ARL102-LRA [^]	RPK102-HRZ [^]	TG102C-HQZ [^]	RQF102-FQS [^]	TG102C-JPZ [^]
97	○	○	○	○	○	○	○	○	○
93	○	○	○	○	○	○	○	○	○
86	○	○	○	○	ARL86-LRA [^]	○	TG86C-HQZ [^]	RQF86-FQS [^]	○
76	○	○	○	○	○	○	○	○	○
I_f (A) Rated Current	15	30	25	15	30	15	15	10	20
U_f (VDC) [^] Rated Voltage	850		600		500		450		400
U_f (VAC) [*] Rated Voltage	○	○	○	○	○	○	○	○	○
Product Structure									
	Axial Shape	Radial Shape	Radial Shape	Radial Shape	Axial Shape	Radial Shape	Axial Shape	Radial Shape	Axial Shape

Direct Current Thermal-Link Alloy Type (DC-ATCO) Features & Model List Overview

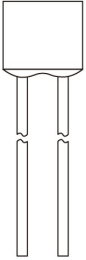
Rated Functioning Temp. (T_r) °C	Model											
	TG150C-JSZ*				HN150^*	HP150^*	HS150^*		QD150^	PD150^	TD150^	SD150^
230	○	○	○	○	○	○	○	○	○	○	○	○
221	○	○	○	○	○	○	○	○	○	○	○	○
205	○	○	○	○	○	○	○	○	○	○	○	○
200	○	○	○	○	○	○	○	○	○	○	○	○
187	○	○	○	○	○	○	○	○	○	○	○	○
160	○	○	○	○	○	○	○	○	○	○	○	○
150	TG150C-JSZ*	○	○	○	HN150^*	HP150^*	HS150^*	○	QD150^	PD150^	TD150^	SD150^
145	○	○	○	○	○	○	○	○	○	○	○	○
139	○	○	○	○	○	○	○	○	○	○	○	○
136	TG136C-JSZ*	○	○	○	HN136^*	HP136^*	HS136^*	○	QD136^	PD136^	TD136^	SD136^
135	○	○	○	○	○	○	○	○	○	○	○	○
133	○	○	○	○	○	○	○	○	○	○	○	○
130	○	○	○	○	○	○	○	○	QD130^	PD130^	TD130^	SD130^
125	TG125C-JSZ*	○	○	○	HN125^*	HP125^*	HS125^*	ALP125-PLZ^	QD125^	PD125^	TD125^	SD125^
123	○	○	○	○	○	○	○	○	○	○	○	○
120	○	○	○	○	○	○	○	○	○	○	○	○
115	TG115C-JSZ*	○	○	ALP115-HLZ^	○	○	○	○	QD115^	PD115^	TD115^	SD115^
105	○	○	○	○	○	○	○	○	○	○	○	○
102	TG102C-JSZ*	○	○	○	○	○	○	ALP102-PLZ^	QD102^	PD102^	TD102^	SD102^
97	○	○	○	○	○	○	○	○	○	○	○	○
93	○	○	○	○	○	○	○	○	○	○	○	○
86	○	TG86C-HSZ*	RPF86-FPF^	○	○	○	○	○	○	○	○	○
76	○	○	○	○	○	○	○	○	○	○	○	○
I_r (A) Rated Current	20	15	10	15	15	10	5	60	20	15 16	10	25
U_r (VDC)^ Rated Voltage	○	○	400	○	200	○	○	180	○	○	125	○
U_r (VAC)^* Rated Voltage	600	○	○	○	690	500	○	○	○	○	○	○
Product Structure												
	Axial Shape	Radial Shape			Axial Shape						Radial Shape	

Direct Current Thermal-Link Alloy Type (DC-ATCO) Features & Model List Overview

Rated Functioning Temp. (T _r) °C	Model														
	Q136**	Q136*	Q136*	P136**	P136*	P136*	TB136-UHZ^	TB136-UJZ*	TS136-RHZ^	TS136-RJZ*	S136^	T136^	ADN230B-NEZ		
230	○	○	○	○	○	○	○	○	○	○	○	○	○	○	
221	○	○	○	○	○	○	○	○	○	○	○	○	○	○	
205	○	○	○	○	○	○	○	○	○	○	○	○	○	○	
200	○	○	○	○	○	○	○	○	○	○	○	○	○	○	
187	○	○	○	○	○	○	○	○	○	○	○	○	○	○	
160	○	○	○	○	○	○	○	○	○	○	○	○	○	○	
150	○	○	○	○	○	○	○	○	○	○	S150^	T150^	○	○	
145	○	○	○	○	○	○	○	○	○	○	○	○	○	○	
139	○	○	○	○	○	○	○	○	○	○	○	○	○	○	
136	○	○	○	○	○	○	○	○	○	○	○	○	○	○	
135	○	○	○	○	○	○	○	○	○	○	○	○	○	○	
133	○	○	○	○	○	○	○	○	○	○	○	○	○	○	
130	○	○	○	○	○	○	○	○	○	○	○	○	○	○	
125	○	○	○	○	○	○	○	○	○	○	○	○	○	○	
125	Q125**	○	○	P125**	○	○	TB125-UHZ^	TB125-UJZ*	TS125-RHZ^	TS125-RJZ*	○	○	○	○	
123	○	○	○	○	○	○	○	○	○	○	○	○	○	○	
120	○	○	○	○	○	○	○	○	○	○	○	○	○	○	
115	Q115**	Q115*	Q115*	P115**	P115*	P115*	TB115-UHZ^	TB115-UJZ*	TS115-RHZ^	TS115-RJZ*	S115^	T115^	○	○	
105	○	○	○	○	○	○	○	○	○	○	○	○	○	○	
102	Q102**	○	○	P102**	P102*	P102*	TB102-UHZ^	TB102-UJZ*	TS102-RHZ^	TS102-RJZ*	S102^	T102^	○	○	
97	○	○	○	○	○	○	○	○	○	○	○	○	○	○	
93	○	○	○	○	○	○	○	○	○	○	○	○	○	○	
86	○	○	○	○	○	○	○	○	○	○	○	○	○	○	
76	○	○	○	○	○	○	○	○	○	○	○	○	○	○	
I_r (A) Rated Current	25			20			200		100		10		15 16	50	
U_r (VDC)^ Rated Voltage	120						100		100		100		60		
U_r (VAC)* Rated Voltage	400	300	250	400	300	250	125		125		○		○		
Product Structure															
							Radial Shape						Axial Shape		



Direct Current Thermal-Link Alloy Type (DC-ATCO) Features & Model List Overview

Rated Functioning Temp. (T _r) °C	Model																				
	R31 ^Λ *	U31 ^Λ *						C31 ^Λ *					B31 ^Λ *	H31 ^Λ *	V31 ^Λ *	V31*		X31*	K31*		
230	○	○	○	○	○	○	○	○	○	○	○	○	○	○	○	○	○	○	○	○	○
221	R32 ^Λ *	U32 ^Λ *						C32 ^Λ *					B32 ^Λ *	H32 ^Λ *	V32 ^Λ *	V32*		X32*	K32*		
205	○	○	○	○	○	○	○	○	○	○	○	○	○	○	○	○	○	○	○	○	○
200	○	○	○	○	○	○	○	○	○	○	○	○	○	○	○	○	○	○	○	○	○
187	○	○	○	○	○	○	○	○	○	○	○	○	○	○	○	○	○	○	X17 ^Λ *	K17 ^Λ *	
160	R16 ^Λ *	U16 ^Λ *						C16 ^Λ *						H16 ^Λ *	V16 ^Λ *			X16 ^Λ *	K16 ^Λ *	F16*	
150	R7 ^Λ *	U7 ^Λ *																X7*	K7*	F7*	
145	R6 ^Λ *	U6 ^Λ *	C6 ^Λ							X6 ^Λ							K6 ^Λ	F6 ^Λ	X6*	K6*	F6*
139	○	CR13 ^Λ	○	M13 ^Λ	C13 ^Λ				SF13 ^Λ	V13 ^Λ								F13 ^Λ	○	○	F13*
136	○	○	○	○	○	○	○	○	○	○	○	○	○	○	○	○	○	K9 ^Λ	X9*	K9*	○
135	R5 ^Λ *	U5 ^Λ *																	X5*	K5*	○
133	○	○	○	○	○	○	○	○	○	V8 ^Λ	SF8 ^Λ							F8 ^Λ	X8*	K8*	F8*
130	R4 ^Λ *	U4 ^Λ *								V4 ^Λ	SF4 ^Λ							F4 ^Λ	X4*	K4*	F4*
125	R3 ^Λ *	U3 ^Λ *												H3 ^Λ *				X3 ^Λ *	K3 ^Λ *	F3*	
123	○	○	○	○	○	○	○	○	○	○	○	○	○	○	○	○	○	○	○	○	○
120	○	○	○	○	○	○	○	○	○	○	○	○	○	○	○	○	○	○	○	○	○
115	R2 ^Λ *	U2 ^Λ *				C2 ^Λ				V2 ^Λ	SF2 ^Λ							F2 ^Λ	X2 ^Λ *	K2 ^Λ *	F2*
105	○	○	○	○	○	○	○	○	○	○	○	○	○	○	○	○	○	○	○	○	○
102	R1 ^Λ *	U1 ^Λ *																F1 ^Λ	X1 ^Λ *	K1 ^Λ *	F1*
97	○	○	○	○	○	○	○	○	○	○	○	○	○	○	○	○	○	○	○	○	○
93	○	○	○	○	○	○	○	○	○	○	○	○	○	○	○	○	○	○	○	○	○
86	R18 ^Λ *	U18 ^Λ *					C18 ^Λ							V18 ^Λ				F18 ^Λ	X18 ^Λ *	K18 ^Λ *	F18*
76	R0 ^Λ *	U0 ^Λ *																X0*	K0*	F0*	

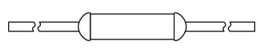
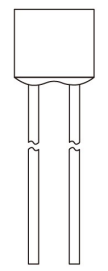
I_r (A) Rated Current	15	10	9	8.5	8	6	5	4	3	2.5	2	1	4	3	2	1	
U_r (VDC)^Λ Rated Voltage	60																
U_r (VAC)[*] Rated Voltage	250	250				250			250		250	125			250		

Product Structure		
	Axial Shape	Radial Shape

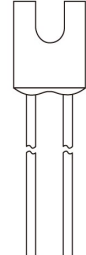
Direct Current Thermal-Link Alloy Type (DC-ATCO) Features & Model List Overview

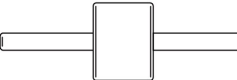
Rated Functioning Temp. (T_r) °C	230											ADN230B-NDZ ^Δ	ADN230B-PDZ ^Δ			ADN230B-QBZ ^Δ	
	221	XG31*	KG31*			C31*	B31*	H31*							ADN205B-NDZ ^Δ		
	205	XG32*	KG32*			C33*	B32*	H32*									
	200																
	187																
	160	XG16*	KG16*			B16*											
	150	XG7*	KG7*	C7 ^Δ	C7*	B7 ^{Δ*}	H7 ^{Δ*}		V7 ^{Δ*}								
	145	XG6*	KG6*	C6 ^Δ	C6*	B6 ^{Δ*}	H6 ^{Δ*}		V6 ^{Δ*}								
	139			C13 ^Δ	C13*	B13 ^{Δ*}	H13 ^{Δ*}		V13 ^{Δ*}								
	136	XG9*	KG9*	C9 ^Δ	C9*	B9 ^{Δ*}	H9 ^{Δ*}		V9 ^{Δ*}								
	135	XG5*	KG5*	C5 ^Δ	C5*	B5 ^{Δ*}	H5 ^{Δ*}		V5 ^{Δ*}								
	133	XG8*	KG8*	C8 ^Δ	C8*	B8 ^{Δ*}	H8 ^{Δ*}		V8 ^{Δ*}								
	130	XG4*	KG4*	C4 ^Δ	C4*	B4 ^{Δ*}	H4 ^{Δ*}		V4 ^{Δ*}								
	125	XG3 ^{Δ*}	KG3 ^{Δ*}	C3 ^Δ	C3*	B3 ^{Δ*}	V3 ^{Δ*}										
	123																
	120																
	115	XG2 ^{Δ*}	KG2 ^{Δ*}	C2 ^Δ	C2*	B2 ^{Δ*}	H2 ^{Δ*}		V2 ^{Δ*}								
	105																
	102	XG1 ^{Δ*}	KG1 ^{Δ*}	C1 ^{Δ*}	C1*	B1 ^{Δ*}	B1*	H1 ^{Δ*}	H1*	V1 ^{Δ*}	V1*						
	97					C21 ^{Δ*}	B21 ^{Δ*}	H21 ^{Δ*}		V21 ^{Δ*}							
	93																
	86	XG18 ^{Δ*}	KG18 ^{Δ*}	C18 ^{Δ*}	C18*	B18 ^{Δ*}	B18*	H18 ^{Δ*}	H18*	V18 ^{Δ*}	V18*						
	76	XG0*	KG0*	C0*	B0*	B0*	H0 ^{Δ*}	H0*	V0 ^{Δ*}	V0*							
I_r (A) Rated Current	3	2	7	5	3	2		1	50		55	50	80				
U_r (VDC)^Δ Rated Voltage	60												49	48	24		
U_r (VAC)[*] Rated Voltage	250		250	125	250	125	250	125	250	125			250				
Product Structure																	
	Radial Shape										Axial Shape						